

NX3 Evo Flight Controller System Manual

VERY IMPORTANT!

- Please release or turn off the emergency switch when the plane become level flight and under control. Emergency mode just for emergency situations.
- Please use good quality BEC or ESC as power supply. Do not use Ni-Mh and dry cell batteries.
- When use NX3evo in Delta wing or V-tail plane, please turn off mixers on your transmitter, and set the DIP switch on NX3evo.
- For the first flying, it's better to keep a lower sensitivity (-20%~+20% gain, 10~14 o'clock is recommend) and then increase it gradually.
- Check every axis gain direction before flight.
- When you trigger the emergency switch, The elevator will move up and then move down slowly. If it is not, please reset this function refer step 4.8 radio stick direction calibration.
- Must keep the plane level and stable when power on the system.
- When switching on the radio control system it is essential to keep the transmitter aerial at least 15 cm away from the receiver aerials at all times. Otherwise, NX3evo will read the wrong center position of receiver signal.
- The Controller has to re-learn center position after installation, or replacing a new radio system, or making a trimming (or Sub-Trim) change within the transmitter, otherwise the servos may move to one side automatically. To do this, just quickly flip the flight mode switch twice within 1 second!

1. Features:

- NX3evo provides four levels of flight mode: 1. Beginner, 2. Practice, 3. Promotion, 4. Expert.
- Four Model Types supported: single aileron, dual ailerons, delta and vtail.
- Two kinds of Gain Control Method supported: Master Gain from the radio, Independent Axis Gain from the Variable resistor on the Controller board.
- Emergency mode guarantee safety flight.
- Automatic aileron levelling.
- 3D AVCS flight, Attitude locking.
- Provide Y-wiring for aileron.

2. Specifications:

- Voltage range: DC 4.5 - 6V
- Response Frequency: 100Hz
- Operating Temperature: 0-50°C
- Size: 43x28x15mm
- Weight: 11g

3. Packing List:

- NX3evo Flight Controller Board
- NX3evo Manual
- Connector wires
- Double-sided paste
- Mini Screwdriver

4. Installation:

WARNING: PLEASE READ THE FOLLOWING STEPS VERY CAREFULLY BEFORE YOU START TO INSTALL A NEW PLANE!

Step 1: Configure the plane without NX3evo.

Create a new model in your transmitter. Do not engage any mixer on your transmitter. Assign two switches for NX3evo. One is for AUX (flight mode change), two or three steps. Another is for Emergency (Rebound Toggle Switch is better). Make sure all servos move smoothly.

Step 2: mount

NX3evo need to be firmly mounted near the gravity center of the plane with provided

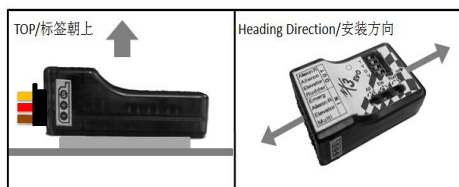

double-tape. Please make sure the long side of NX3evo is in line with the fuselage. And the logo side should face up. **After mounting, please check again whether the board is firmly attached to the aircraft.**

Step 3: DIP configure

1. If you are a beginner, please turn the switch (T) to the right.
2. If you want yaw attitude locking, please turn the switch (Y) to the right.
3. For delta-wing plane, please turn the switch (D) to the right.
4. For v-tail plane, please turn the switch (V) to the right.

Step 4: Wiring

Connect NX3evo and the receiver using wires in the package according to the following figure.

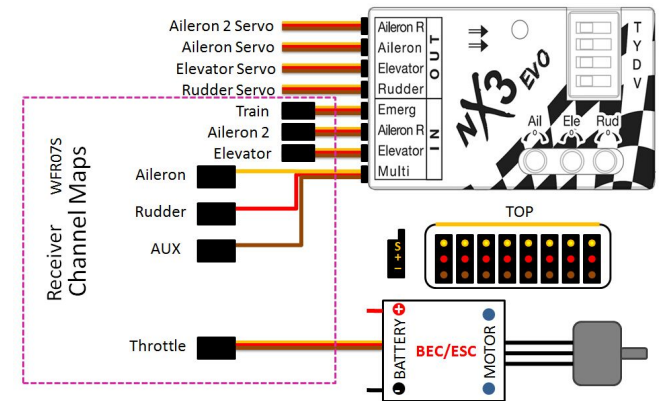

Step 5: AUX Channel or Master Gain channel Setting

NX3evo use AUX channel to change flight mode. The travel of AUX channel also control the Master Gain of NX3evo. Decrease the AUX travel will decrease all three axes correction. NX3evo will be in Beginner Level or Expert Level if AUX channel do not connect to the receiver.

	'T' be right side		'T' be left side			Emergency Signal With
mode	Beginner	Practicing	Promotion	Expert	Close	100
AUX Signal Width	-100 ~ 0	0 ~ 100	0 ~ 100	-100 ~ 0	0	Emergency Mode
LED Status	forever on	Fast Flash	Fast Flash	forever on	off	Slow Flash

Step 6: Individual Correction Gain and Correct Direction Configuration

Using the provided screwdriver to adjust the gain pots on NX3evo board control the correctional gain (sensitivity) and correct direction for the following controls: pitch (ELE), roll (AIL) and yaw (RUD) axis. You'd better start with a lower sensitivity for your first flight (-20%~+20% gain was recommend) and then increase it gradually. The aircraft will become vibrative if the gain is too large.

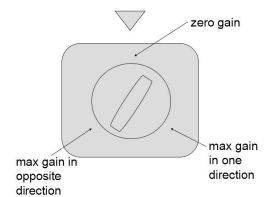

Before configure the Correct Direction, please switch to Practicing Level or Promotion Level at first, power on the system, pick up the airplane and check it by following the three steps below:

AILERON Quickly move the right wing upward around the roll axis, the right aileron will flap up and the left flap down.

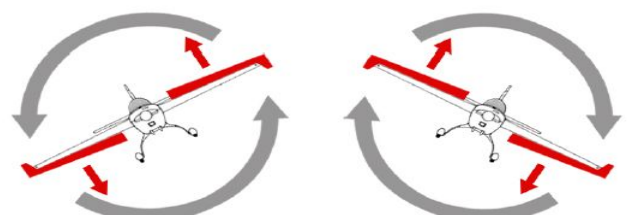

ELEVATOR Quickly move the tail upward around the pitch axis, the elevator will flap up as shown.

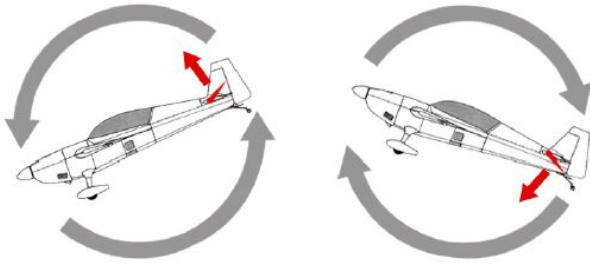

RUDDER Quickly move the tail to the right around the yaw axis, the rudder will turn to the right as shown.

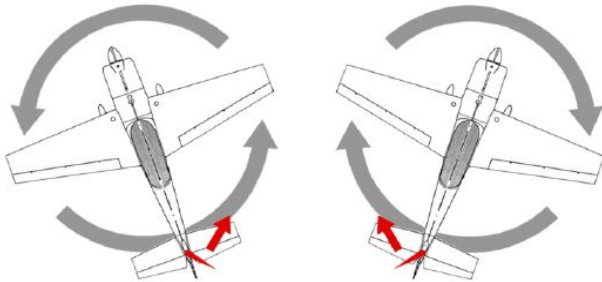

Step 7: Emergency Mode (must connect the emergency cable) configuration

The emergency mode need an assigned switch in your transmitter (Rebound Toggle Switch is better).Toggle the switch to activate the emergency function(switch channel signal 100).When you release or turn off the emergency switch(switch channel signal less than 100),NX3evo will return to the previous flight mode.When Emergency Mode activate, the plane will flying level and up rapidly for about 3 seconds.If you do not release or turn off the emergency switch ,the plane keep roll levelling and pitch climbing flying attitude.

Step 8: Radio Stick Direction Calibration

When active emergency mode, the ELE will flap up and return original level slowly. If it is not, you must calibrate the direction of your radio stick follow the steps below.

1. Please refer the picture on the right: move the switch 'D' & 'V' on the right side, and switch 'T' & 'Y' on the left side.
2. Power on the radio and NX3evo, wait patient until NX3evo LED flashing slowly. Then move the two stick to the lower left corner and hold this position until the LED turns off. That means the calibration is done.
3. Re-set the DIP refer to 4.3.

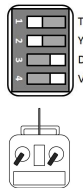

5. Dual Aileron Setting

NX3evo support single aileron signal and dual aileron signal.If the Aileron R IN cable be attached to the receiver ,Dual Aileron function will active automatively. NX3evo also support Y-cable function if the Aileron R IN cable not be connected to the receiver.

NOTE: if Dual Aileron function activated, please don't use the beginner mode simultaneously.

6. Re-learn center position

The Controller has to re-learn center position after installation,or replacing a new radio system, or making a trimming(or Sub-Trim)change within the transmitter, otherwise the servos may move to one side automatically.To do this,just quickly flip the flight mode switch twice within 1 second!

7. Flight mode details:

1. Beginner mode

feature: Aileron auto-level . roll angle limit to ± 75 degree. When the aileron stick back to center position, the aileron will keep level automatically. The elevator will be control by yourself, there is no auto-level function. But will provide obvious assist,the pitch have attitude locking function. Beginner mode is for very beginner player.Also can be used for short-range FPV.

2. Practice mode

feature: attitude locking for roll,pitch,yaw.restriction on roll and pitch speed. Practice mode do not have auto-level and angle limit function. Practice mode is for practise flying. If you want yaw attitude locking, please refer 4.3 DIP configure.

3. Promotion mode

feature: attitude locking for roll,pitch,yaw. Promotion mode is very likely from practice mode.It provide attitude locking function.Compare to practice mode,promotion mode supply more sensitive sense of control . If you want yaw attitude locking, please refer 4.3 DIP configure.

4. Expert mode

feature: simple Gyro correction.The best control sense. It supply a simple Gyro correction and anti-wind function.

5. Emergency mode

feature: Roll auto-level,climb up. You can triggler the emergency switch in beginner mode,practice mode,promotion mode and expert mode to activate emergency mode.In emergency mode,aircraft will keep roll level and then climb up by a small degree.